

## Strength Comparison - MASONRY vs. Wood Frame

### LOWERING DESIGN VALUES for SOUTHERN PINE



**Wood frame construction in Florida has a problem.** Actually, wood frame construction in Florida has numerous problems: higher insurance costs, fire; termites; rot from moisture leakage and condensation inside the wall just to name a few. But those are not the topic for today.

**Wood frame structures have a serious problem with their poor performance in Florida wind storms compared with their largest competitor – Concrete Masonry.** 20 years ago, after Hurricane Andrew, Florida's building codes were upgraded to provide more structural integrity for residential structures. Increased safety factors were mandated for both masonry and wood construction to ensure wind protection. Since that time masonry has performed without so much as a "block out of place". **Unfortunately, wood frame structures have continued to suffer damage in both Florida hurricanes and tornadoes that simply should not be happening with the mandated increases in structural requirements.**

A possible explanation for this poor performance of wood frame has recently surfaced with an **unprecedented downgrade to Southern Pine structural design values.** As of June 1<sup>st</sup>, 2012 this downgrade will effect "No. 2 2x4 visually graded lumber and all lower grades of this size"<sup>1</sup>.

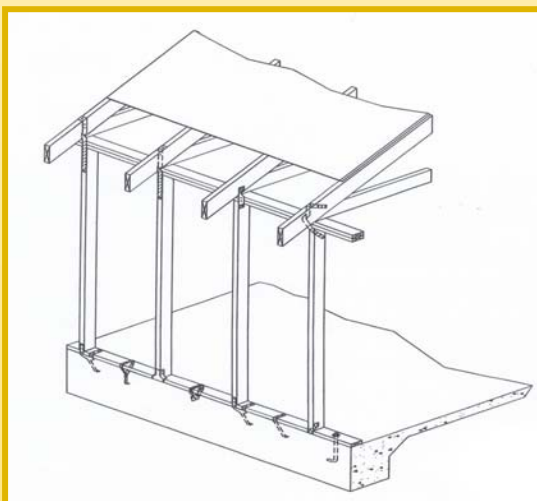

Figure 1 – Typical Wood Frame Construction



This beautiful Florida home was built with 100% concrete masonry wall construction!

This lumber size and classification represents a significant amount of wood materials currently used in Florida walls and it is understood that the downgrade will soon extend to every size and classification of Southern Pine <sup>2</sup>.

The downgrade comes from the American Lumber Standard Committee (ALSC), the organization that controls wood design values in the United States. On January 11, 2012 the ALSC issued their decision stating "**it (the ALSC Board) cautions all interested parties to take note of all available information in making design decisions in the interim.** The values in the SPIB (Southern Pine Inspection Bureau) proposal represent approximately a 25-30% reduction."<sup>1</sup> Also, "**All design professionals are advised in the strongest terms by the Board to evaluate this information in formulating their designs in the interim period.**"<sup>1</sup> The bold and underlines actually appear in the

*“ Build with concrete masonry and have the piece of mind in knowing you are truly sheltered from the storm. ”*

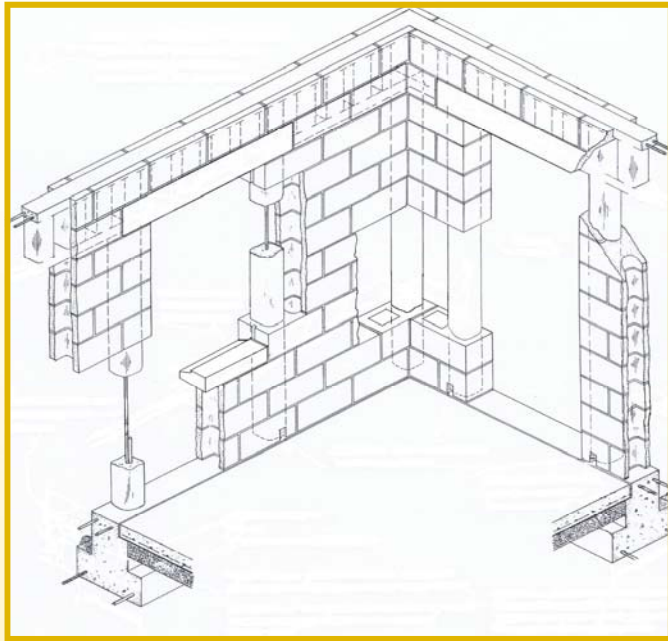

Figure 2 – Concrete Masonry Wall Construction

issued ALSC Board document and the “interim period” mentioned is until the entire range of wood product testing is complete.

Wood frame structures have always suffered from a connection problem. The difficulty comes from trying to tie together all of the individual pieces of lumber making up a wood structure. The typical wood frame home contains roughly 2000 nails and connectors. Making sure all of these connectors are installed properly is a huge and complicated task. The failure of even a handful of these connectors can and HAS BEEN catastrophic in the actual performance of wood structures under wind load. Think about trying to connect a severed 6” diameter branch back onto a tree with it’s original strength!

**These complicated connections combined with the recent discovery that wood only possesses a fraction of the strength previously attributed to it brings the poor performance of wood structures into a clearer focus.**

Concrete Masonry construction offers a clearly superior or alternative to the structural weakness of wood frame. Connections are made with steel bars and concrete grout.

Because of advances in manufacturing and installation, structural design values of concrete masonry have actually increased<sup>3</sup>. While costs are extremely competitive, the superior performance of concrete masonry is overwhelming and costs for wood frame will be increasing due to the decrease in the 2 x 4 design values.

**Why invite trouble into your home?**

**Build with concrete masonry.**

**Contact the Masonry Association of Florida for more information:**



[www.FloridaMasonry.com](http://www.FloridaMasonry.com)

References:

- 1 American Lumber Standard Committee, Inc. (ALSC) Board of Review Supplement 9 Ruling – January 11, 2012.
- 2 “Submission of Interim Design Values for Visually Graded Southern Pine Dimension Lumber (Based on tests of 2x4 No.2 Lumber)” - Southern Pine Inspection Bureau September 2011 (Revised December 2011)
- 3 TMS 402 - 2011 Edition

Additional Resources:

Supplement No. 9 to the Southern Pine Inspection Bureau 2002 Grading Rules

“The Effect of Proposed Changes to Southern Pine on Simpson Tie Connectors & Fasteners” – Simpson String-Tie Co., Inc.  
[www.strongtie.com](http://www.strongtie.com)

**VISIT** our  
**WEBSITE**

[www.FloridaMasonry.com](http://www.FloridaMasonry.com)